

SPEED IRREGULARITY CHARACTERISTIC OF LOW SPEED, TWO - STROKE MARINE DIESEL ENGINE APPLIED AS VESSEL'S MAIN PROPULSION

Przemysław Kowalak

Maritime University of Szczecin - Department of Engineering
Waly Chrobrego 1-2, 70-500 Szczecin, Poland
tel.: + 48 91 4809400, fax: +48 91 4809575
e-mail: pkowalak@am.szczecin.pl

Abstract

The piston engine irregularity is a consequence of the uneven power supply from the engine units. As such it contains valuable information about engines units working process. Unfortunately it is strongly influenced by torsional vibration, resonance, and propeller behavior. In order to better understand the speed irregularity phenomena the instantaneous speed was recorded and its characteristic against engine mean speed was developed. Some statistical parameters: standard error and deviation as well as variance were determined. The results were compared with propulsion plant torsional vibration. The presented results show that the irregularity of the long stroke engine's speed is strongly influenced by torsional vibration phenomena. The analyzed engine has a bared speed range 37-43 rpm. Exactly around that range the speed irregularity reaches its maximum values of 18% of mean speed. The analysis can be considered as qualitative look into the phenomena. However even based on the presented analysis one can observe some practical inferences. The common type of electronic indicators is used to simplify the measurement by assuming that the shaft speed is equal in between the pickup pulses. In order to increase the accuracy of the indicated power determination the use of such instrument should be avoided in the speed range which is a multiple number of the barred speed. Due to the fact that the shaft speed is irregular especially in the ranges where torsional resonance may occur the piston positioning (for example for TDC determination) purpose procedure should take it into account.

Keywords: transport, marine diesel engines, combustion processes, speed measurement, speed irregularity

1. Introduction

The torsional vibration of the vessel's propulsion shaft is particularly supervised by the Ship's Classification Societies [3, 5]. As the energy in the piston engine is provided periodically and the shaft speed of the ship's main propulsion engines is low, the risk of resonance with the shaft's free vibration emerges. In [6] the MAN B&W company estimates that due to resonance the shaft's tangential stress may reach even from 5 up to 50 times higher value than the stress at nominal load. To protect the shafting against damage the Classification Societies set two levels of allowed stress [6] which are usually called τ_1 and τ_2 (Fig. 1). The propulsion set is allowed to operate below the level τ_1 without any limitations; however, the generated vibrations may be unpleasant for the crew or even harmful for some of the ship's equipment. In case the level τ_1 is exceeded the barred speed range has to be applied as a countermeasure. The engine can be operated in this range only for a very short time necessary to pass up quickly to above or down to below the barred speed.

If the higher level of stress τ_2 is exceeded the engine will be totally banned from operation in the range of speed when excessive stress is observed. When the new propulsion unit is being designed the constructor has to pay particular attention to avoid the exceeding of τ_2 in the engine's operational speed range. In some cases the torsional vibration damper may be helpful to reduce the stress down to below the τ_2 .

The variable tangential stress in the shaft line is the consequence of the variable torque between the engine and propeller. The torque applied to the shaft is twisting it according to the

formula:

$$\varphi = \frac{M \cdot l}{G \cdot I_o}, \quad (1)$$

When the anti-torque generated by the propeller is smaller than the torque produced by the engine the shaft line is forced to rotate. In the theoretical situation of balance between the torque and anti-torque the rotational shaft speed would be constant. In fact the propeller's anti-torque fluctuates and the engine produces highly pulsating torque. As a consequence the shaft rotates with variable angular speed which can be described as:

$$\omega_{(t)} = \frac{d\varphi_{(t)}}{dt}, \quad (2)$$

By means of the Fourier transform the constant component of the angular speed can be distinguished and an infinite amount of the periodic components as well. Those periodic components are responsible for the phenomena called irregularity of the shaft rotational speed. As it was presented above the shaft's rotational speed irregularity can be related to its tangential stress.

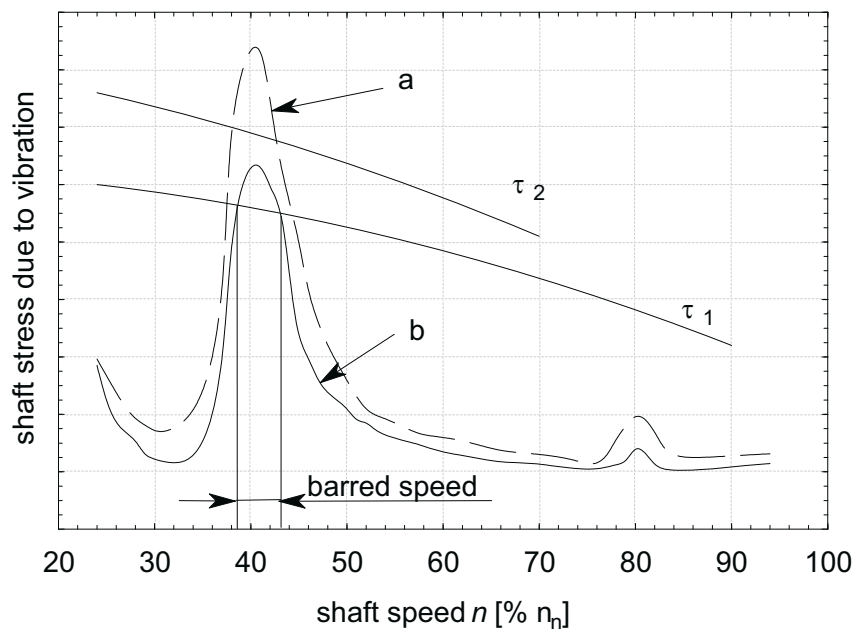

Fig. 1. Shaft stress and barred speed range over a marine engine speed

The instantaneous values of the shaft speed and the torque oriented to instantaneous piston position determination lays in the field of the author's interest. So the possibility of the low speed, two - stroke marine diesel engine's speed irregularity characteristic analysis appeared as very interesting.

2. The propulsion plant and the measurement conditions

The measurement was carried out on the 1719 TEU container ship. As the prime move the long stroke, low speed MAN 6L70ME - C engine was installed. The engine drives the ship's constant pitch propeller directly. The installed propulsion plant allows the ship to reach contract speed of 21 knots. The diagram of the propulsion plant is shown on Fig. 2a and its basic technical data in Tab. 1.

Tab. 1. Basic technical data of the propulsion plant

Denomination	Value
Engine's nominal power	16980 kW
Engine's nominal speed	98.3 min ⁻¹
Propeller's shaft diameter	579 mm
Propeller diameter	6700 mm
Propeller's blades number	5
Barred speed range	37-43 rpm

To eliminate sea condition influence on the measurement results the experiment was conducted in the equatorial area only, with the sea state 3 or lower. The influence of the ship's load condition was not tested.

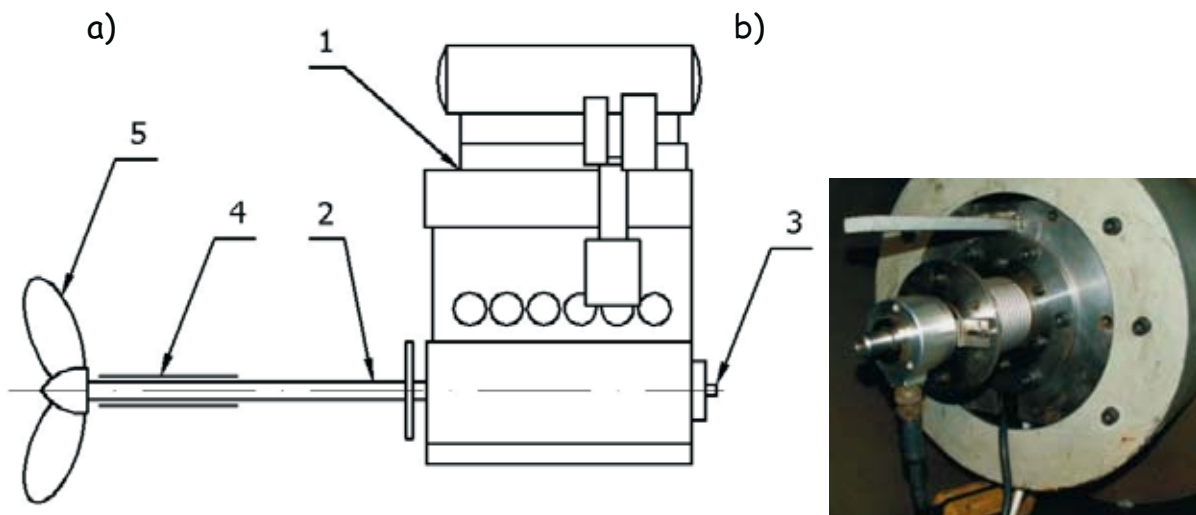

Fig. 2. The propulsion plant: a) schematic diagram; 1.Main engine; 2.Propulsion shaft; 3. Rotary incremental encoder; 4. Stern tube with stern bearings; 5. Propeller; b) Encoder attached to the crankshaft

The main engine is of the electronic control type. The fuel injection and exhaust valve are hydraulically actuated and controlled by designated digital multipurpose controllers (MPC). The MPC utilizes the signal from an incremental encoder for the crankshaft's positioning. The encoder is attached to the crankshaft free end by means of a bellows clutch (Fig. 2b). As the encoder generates 360 pulses of TTL standard per revolution it was possible to utilize the signal for precise rotation speed measurement. The used measurement instrumentation is presented in the Tab. 2.

Tab. 2. Measurement instrumentation data

Instrument	Type
Measurement board	NI USB-6221, National Instruments, with counter input gate
Encoder	Incremental encoder ITD. 44 A 4 Y134, MAN B&W

The methodology described in [7] by Piętak was utilized for instantaneous speed determination. The encoder's TTL signal was connected directly to the digital counter input gate of the measurement board, then the signal was compared with a fast, 80 MHz, on-board frequency generator. In such a way the difficult analog signal of fast sampling was avoided. As a result the time of one period of TTL signal was generated. A schematic diagram of the measurement is presented in Fig 3.

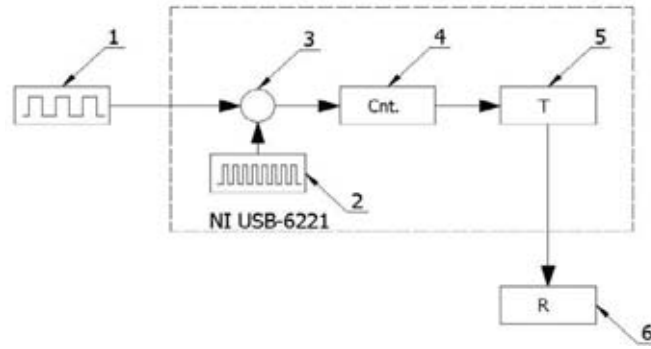

Fig. 3. Measurement basics; 1. Input signal from encoder; 2. On board, 80MHz pulse generator; 3. Trigger and reset modulus; 4. Pulse counter; 5. Pulse number to period converter; 6. Signal recorder

3. Statistical speed analysis

The measured signals were recorded at different speed settings of the main engine. The signals were divided into segments including one complete engine working cycle. The example of the speed course for 3 consecutive engine cycles is presented on Fig 4.

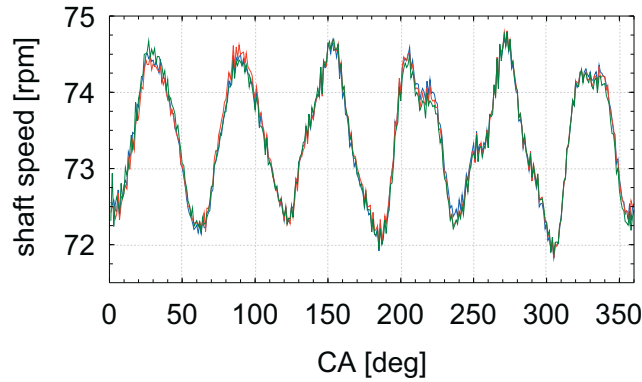

Fig. 4. Shaft speed course over its angular position

For every engine cycle the maximum, minimum and a mean value of the speed was determined. And the speed irregularity was calculated as following:

$$\delta_n = \frac{n_{\max} - n_{\min}}{\bar{n}}, \quad (3)$$

In order to get a more precise statistical image of the rotational speed alteration a standard deviation, variance and standard error of the mean value was calculated additionally [1]:

$$s_n = \sqrt{\frac{1}{k} \sum_{i=1}^k (n_i - \bar{n})^2}, \quad (4)$$

$$s_n^2 = \frac{1}{k} \sum_{i=1}^k (n_i - \bar{n})^2, \quad (5)$$

$$SE_n = \frac{s_n}{\sqrt{k}}. \quad (6)$$

Heywood [4] proposed to apply a coefficient of variation in indicated mean effective pressure as an evaluation of indicated work variability. The coefficient is equal to the standard deviation error to the mean value ratio. As the speed irregularity can be determined for every engine cycle separately as well, the coefficient of variation in instant engine speed was calculated adequately:

$$X_n = \frac{s_n}{n} \cdot 100\% . \quad (7)$$

Based on the presented formulas the characteristics were drawn versus the engine's crankshaft rotation speed (Fig. 5).

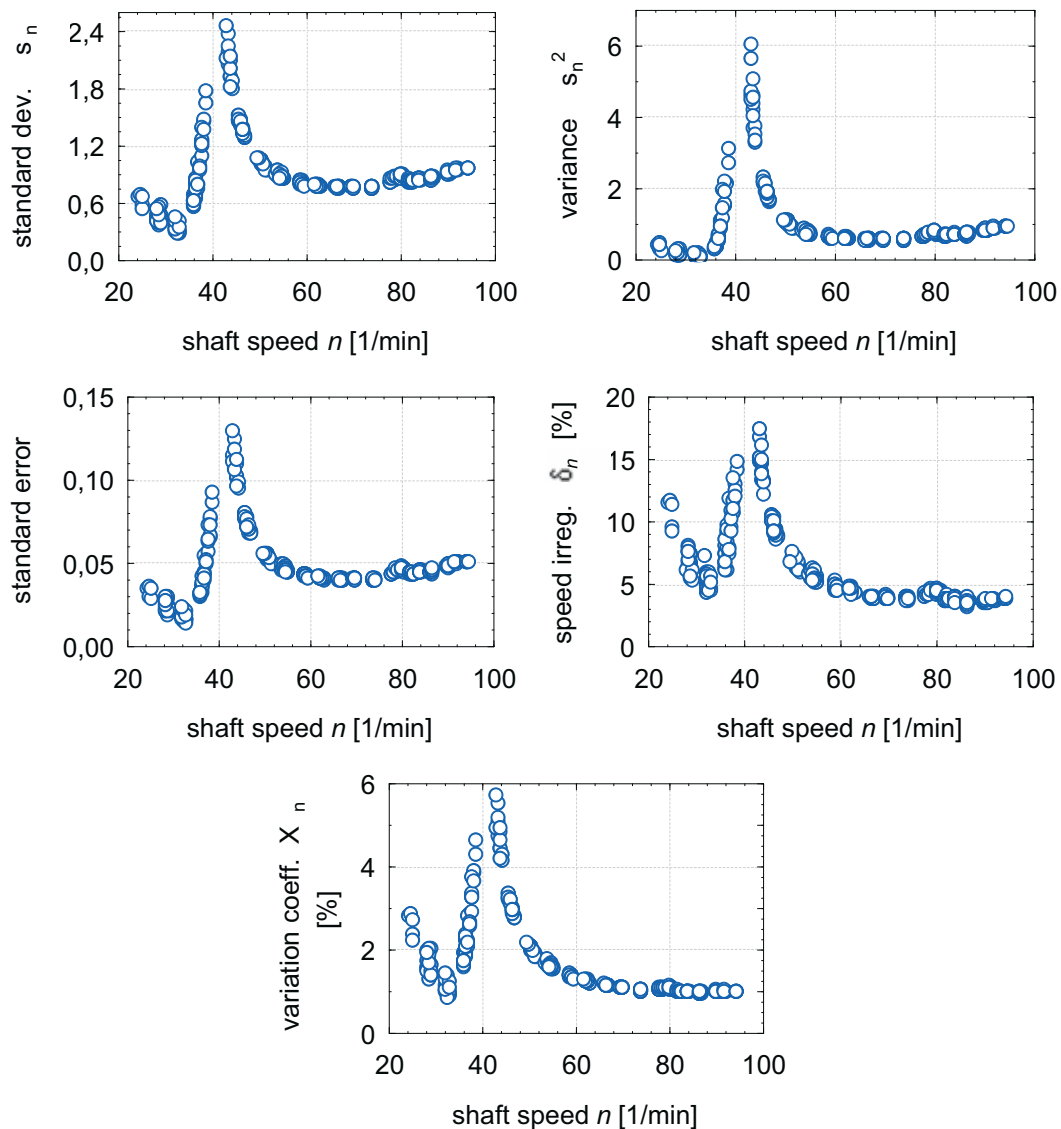

Fig. 5. Calculated statistical parameters versus shaft speed

4. Conclusion

The presented results show that the irregularity of the long stroke engine's speed is strongly influenced by torsional vibration phenomena. The analyzed engine has a bared speed range 37-43 rpm. Exactly around that range the speed irregularity reaches its maximum values of 18% of mean speed. Other, additionally calculated, statistical parameters show similar behavior. It is worth to notice that a small peak can be observed in the range of 78-82 rpm range which is twice the barred speed range. In that range of speed an unpleasant extra vibration on board the ship was

observed. This range was usually omitted by navigation officers as disturbing noise and vibration of equipment occurred then. It can be observed that the irregularity increases when the engine speed approaches the speed level of 20 rpm, too. As the engine's operation range of speed is 24-98 rpm the test for a very low speed close to 20 rpm was impossible.

The analysis can be considered as qualitative look into the phenomena. However even based on the presented analysis one can observe some practical inferences. The common type of electronic indicators is used to simplify the measurement by assuming that the shaft speed is equal in between the pickup pulses [2, 8]. In order to increase the accuracy of the indicated power determination the use of such instrument should be avoided in the speed range which is a multiple number of the barred speed.

Due to the fact that the shaft speed is irregular especially in the ranges where torsional resonance may occur the piston positioning (for example for TDC determination) purpose procedure should take it into account.

Nomenclature

- φ angle of shaft line twisting or rotation,
- T torque,
- l shaft measure distance,
- G shear modulus of shaft material,
- I_o shaft line mass moment of inertia,
- $\omega_{(t)}$ angular speed of the shaft,
- t time,
- δ_n speed irregularity,
- n_{min} minimum shaft speed in working cycle,
- n_{max} maximum shaft speed in working cycle,
- k number of encoder's pulses per crankshaft revolution,
- s_n standard deviation of the speed in one working cycle,
- s_n^2 variance of the speed in one working cycle,
- SE_n standard error of the speed in one working cycle,
- X_n coefficient of variation of the speed in one working cycle.

References

- [1] Dobosz, M., *Wspomagana komputerowo statystyczna analiza wyników badań*, Warszawa: Akademicka Oficyna Wydawnicza 2004.
- [2] Gałecki, W., Tomczak, L., *Przenośne systemy diagnostyczne dla procesu spalania w okrętowych silnikach wysokoprężnych*, XVIII Międzynarodowe Sympozjum Siłowni Okrętowych, s. 315-322, Gdynia 1996.
- [3] Germanischer, L., *Rules for Classification and Construction, I - Ship Technology, Part 1 - Seagoing Ships, Chapter 2 - Machinery Installations*, Edition 2000.
- [4] Heywood, John. B., *Internal Combustion Engines Fundamentals*, McGraw-Hill International Editions, Singapore 1988.
- [5] Larsen, O. C., Søntvedt, T., *Prevention of Harmful Engine - and Propeller - Induced Vibrations in the Afterbody of Ships.*, Det Norske Veritas Information No. 9, Oslo, August 1972.
- [6] MAN B&W Diesel A/S, *Vibration Characteristics of Two - stroke Low Speed Diesel Engines* 2nd edition revised from P. 8703-165, Copenhagen 1988.
- [7] Piętak, A., Olchowik, W., Trawiński, G., *Analiza możliwości wykorzystania pomiarów chwilowej prędkości obrotowej wału korbowego do oceny stanu technicznego silnika*, XXX Jubileuszowe Ogólnopolskie Sympozjum Diagnostyka Maszyn, Węgierska Górka 2003.
- [8] Wimmer, A., Glaser, J., *Indykowanie silnika*, Warszawa, Instytut Zastosowań Techniki rozdział 9, s. 17-24 2004.